

The 128-bit Blockcipher CLEFIA
Algorithm Specification

Revision 1.0

June 1, 2007

Sony Corporation

NOTICE

THIS DOCUMENT IS PROVIDED "AS IS," WITH NO WARRANTIES WHATSOEVER, INCLUDING ANY WARRANTY OF MERCHANTABILITY, NON-INFRINGEMENT, FITNESS FOR ANY PARTICULAR PURPOSE, OR ANY WARRANTY OTHERWISE ARISING OUT OF ANY PROPOSAL, SPECIFICATION OR SAMPLE.

Acknowledgments

Tetsu Iwata of Nagoya University has contributed to the development of CLEFIA.

Contact

E-MAIL :

clefia-q@jp.sony.com

Postal Address :

Information Technologies Laboratories

Sony Corporation

1-7-1 Konan, Minato-ku, Tokyo 108-0075 Japan

Revision History

June 1, 2007 1.0 revision

Contents

1	Introduction	4
2	Notations	5
3	Definition of $GFN_{d,r}$	6
3.1	F-functions	7
3.2	S-boxes	7
3.3	Diffusion Matrices	11
4	Data Processing Part	12
4.1	Overall Structure	12
4.2	The Numbers of Rounds	12
5	Key Scheduling Part	14
5.1	Overall Structure	14
5.2	Key Scheduling for a 128-bit Key	14
5.3	Key Scheduling for a 192-bit Key	15
5.4	Key Scheduling for a 256-bit Key	16
5.5	Constant Values	19
6	Test Vectors	26
6.1	Test Vectors (Intermediate Values)	27

1 Introduction

This document describes the specification of the blockcipher CLEFIA. CLEFIA is a 128-bit blockcipher with its key length being 128, 192 and 256 bits, which is compatible to AES. CLEFIA consists of two parts: a data processing part and a key scheduling part. CLEFIA employs a generalized Feistel structure with four data lines, and the width of each data line is 32 bits. Additionally, there are key whitening parts at the beginning and the end of the cipher. The numbers of rounds of CLEFIA are 18, 22 and 26 for 128-bit, 192-bit and 256-bit keys, respectively.

2 Notations

This section describes mathematical notations, conventions and symbols used throughout this paper.

$0\mathbf{x}$:	A prefix for a binary string in a hexadecimal form
$a_{(b)}$:	b denotes the bit length of a
$a b$ or $(a b)$:	Concatenation
(a, b) or $(a\ b)$:	Vector style representation of $a b$
$a \leftarrow b$:	Updating a value of a by a value of b
${}^t a$:	Transposition of a vector or a matrix a
$a \oplus b$:	Bitwise exclusive-OR. Addition in $\text{GF}(2^n)$
$a \cdot b$:	Multiplication in $\text{GF}(2^n)$
\bar{a}	:	Logical negation
$a \lll b$:	b -bit left cyclic shift operation
$\mathbf{w}_b(a)$:	For an $8n$ -bit string $a = a_0 a_1 \dots a_{n-1}$, $a_i \in \{0, 1\}^8$, $\mathbf{w}_b(a)$ denotes the number of non-zero a_i s.

3 Definition of GFN_{d,r}

We first define a function GFN_{d,r} which is a fundamental structure for CLEFIA, followed by definitions of a data processing part and a key scheduling part.

CLEFIA uses a 4-branch and an 8-branch generalized Feistel network. We denote d -branch r -round generalized Feistel network employed in CLEFIA as GFN_{d,r}. GFN_{d,r} uses two different 32-bit F-functions F_0 and F_1 whose input/output are defined as follows.

$$F_0, F_1 : \begin{cases} \{0, 1\}^{32} \times \{0, 1\}^{32} & \rightarrow \{0, 1\}^{32} \\ (RK_{(32)}, x_{(32)}) & \mapsto y_{(32)} \end{cases}$$

For d 32-bit input X_i and output Y_i ($0 \leq i < d$), and $dr/2$ 32-bit round keys RK_i ($0 \leq i < dr/2$), GFN_{d,r} ($d = 4, 8$) are defined as follows.

$$GFN_{4,r} : \begin{cases} \{\{0, 1\}^{32}\}^{2r} \times \{\{0, 1\}^{32}\}^4 & \rightarrow \{\{0, 1\}^{32}\}^4 \\ (RK_{0(32)}, \dots, RK_{2r-1(32)}, X_{0(32)}, \dots, X_{3(32)}) & \mapsto Y_{0(32)}, \dots, Y_{3(32)} \end{cases}$$

<p><i>Step 1.</i> $T_0 T_1 T_2 T_3 \leftarrow X_0 X_1 X_2 X_3$</p> <p><i>Step 2.</i> For $i = 0$ to $r - 1$ do the following:</p> <p style="padding-left: 20px;"><i>Step 2.1</i> $T_1 \leftarrow T_1 \oplus F_0(RK_{2i}, T_0),$ $T_3 \leftarrow T_3 \oplus F_1(RK_{2i+1}, T_2)$</p> <p style="padding-left: 20px;"><i>Step 2.2</i> $T_0 T_1 T_2 T_3 \leftarrow T_1 T_2 T_3 T_0$</p> <p><i>Step 3.</i> $Y_0 Y_1 Y_2 Y_3 \leftarrow T_3 T_0 T_1 T_2$</p>
--

$$GFN_{8,r} : \begin{cases} \{\{0, 1\}^{32}\}^{4r} \times \{\{0, 1\}^{32}\}^8 & \rightarrow \{\{0, 1\}^{32}\}^8 \\ (RK_{0(32)}, \dots, RK_{4r-1(32)}, X_{0(32)}, \dots, X_{7(32)}) & \mapsto Y_{0(32)}, \dots, Y_{7(32)} \end{cases}$$

<p><i>Step 1.</i> $T_0 T_1 \dots T_7 \leftarrow X_0 X_1 \dots X_7$</p> <p><i>Step 2.</i> For $i = 0$ to $r - 1$ do the following:</p> <p style="padding-left: 20px;"><i>Step 2.1</i> $T_1 \leftarrow T_1 \oplus F_0(RK_{4i}, T_0),$ $T_3 \leftarrow T_3 \oplus F_1(RK_{4i+1}, T_2),$ $T_5 \leftarrow T_5 \oplus F_0(RK_{4i+2}, T_4),$ $T_7 \leftarrow T_7 \oplus F_1(RK_{4i+3}, T_6)$</p> <p style="padding-left: 20px;"><i>Step 2.2</i> $T_0 T_1 \dots T_6 T_7 \leftarrow T_1 T_2 \dots T_7 T_0$</p> <p><i>Step 3.</i> $Y_0 Y_1 \dots Y_6 Y_7 \leftarrow T_7 T_0 \dots T_5 T_6$</p>
--

The inverse function GFN_{4,r}⁻¹ is obtained by changing the order of RK_i and the direction of word rotation at Step 2.2 and Step 3.

$$GFN_{4,r}^{-1} : \begin{cases} \{\{0, 1\}^{32}\}^{2r} \times \{\{0, 1\}^{32}\}^4 & \rightarrow \{\{0, 1\}^{32}\}^4 \\ (RK_{0(32)}, \dots, RK_{2r-1(32)}, X_{0(32)}, \dots, X_{3(32)}) & \mapsto Y_{0(32)}, \dots, Y_{3(32)} \end{cases}$$

Step 1. $T_0 | T_1 | T_2 | T_3 \leftarrow X_0 | X_1 | X_2 | X_3$
 Step 2. For $i = 0$ to $r - 1$ do the following:
 Step 2.1 $T_1 \leftarrow T_1 \oplus F_0(RK_{2(r-i)-2}, T_0),$
 $T_3 \leftarrow T_3 \oplus F_1(RK_{2(r-i)-1}, T_2)$
 Step 2.2 $T_0 | T_1 | T_2 | T_3 \leftarrow T_3 | T_0 | T_1 | T_2$
 Step 3. $Y_0 | Y_1 | Y_2 | Y_3 \leftarrow T_1 | T_2 | T_3 | T_0$

3.1 F-functions

Two F-functions F_0 and F_1 used by $GFN_{d,r}$ are defined as follows:

$$F_0 : (RK_{(32)}, x_{(32)}) \mapsto y_{(32)}$$

Step 1. $T \leftarrow RK \oplus x$
 Step 2. Let $T = T_0 | T_1 | T_2 | T_3, T_i \in \{0, 1\}^8$
 $T_0 \leftarrow S_0(T_0),$
 $T_1 \leftarrow S_1(T_1),$
 $T_2 \leftarrow S_0(T_2),$
 $T_3 \leftarrow S_1(T_3)$
 Step 3. Let $y = y_0 | y_1 | y_2 | y_3, y_i \in \{0, 1\}^8$
 ${}^t(y_0, y_1, y_2, y_3) = M_0 {}^t(T_0, T_1, T_2, T_3)$

$$F_1 : (RK_{(32)}, x_{(32)}) \mapsto y_{(32)}$$

Step 1. $T \leftarrow RK \oplus x$
 Step 2. Let $T = T_0 | T_1 | T_2 | T_3, T_i \in \{0, 1\}^8$
 $T_0 \leftarrow S_1(T_0),$
 $T_1 \leftarrow S_0(T_1),$
 $T_2 \leftarrow S_1(T_2),$
 $T_3 \leftarrow S_0(T_3)$
 Step 3. Let $y = y_0 | y_1 | y_2 | y_3, y_i \in \{0, 1\}^8$
 ${}^t(y_0, y_1, y_2, y_3) = M_1 {}^t(T_0, T_1, T_2, T_3)$

S_0 and S_1 are nonlinear 8-bit S-boxes, and M_0 and M_1 are 4×4 matrices defined later in this section. In each F-function, two S-boxes are used in the different order, and different matrix is used. Figure 1 shows the construction of the F-functions.

3.2 S-boxes

CLEFIA employs two different types of 8-bit S-boxes: one is based on four 4-bit random S-boxes, and the other is based on the inverse function over $GF(2^8)$.

Tables 1 and 2 show the output values of S_0 and S_1 , respectively. In these tables all values are expressed in a hexadecimal form. For an 8-bit input

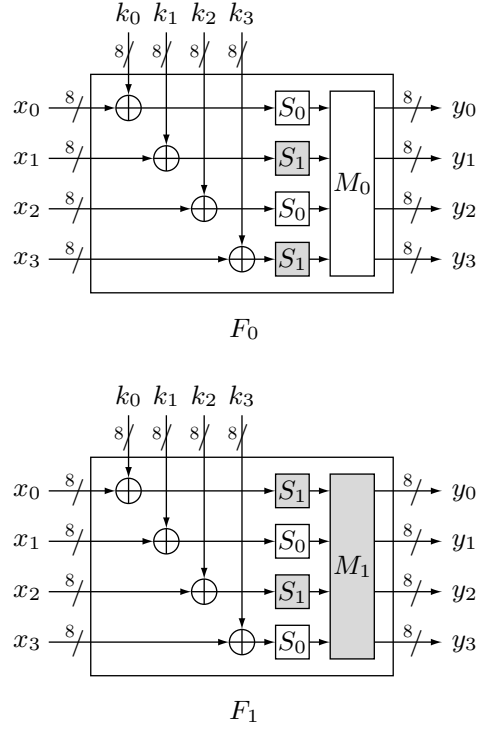

Figure 1: F-functions

of an S-box, the upper 4-bit indicates a row and the lower 4-bit indicates a column. For example, if a value $0xab$ is input, $0x7e$ is output by S_0 because it is on the cross line of the row indexed by 'a.' and the column indexed by '.b'.

3.2.1 S_0

S_0 is generated by combining four 4-bit S-boxes SS_0, SS_1, SS_2 and SS_3 in the following way. The values of these S-boxes are defined as Table 3.

$$S_0 : \begin{cases} \{0, 1\}^8 & \rightarrow \{0, 1\}^8 \\ x_{(8)} & \mapsto y_{(8)} \end{cases}$$

Step 1. $t_0 \leftarrow SS_0(x_0), \quad t_1 \leftarrow SS_1(x_1)$, where $x = x_0|x_1, x_i \in \{0, 1\}^4$

Step 2. $u_0 \leftarrow t_0 \oplus 0x2 \cdot t_1, \quad u_1 \leftarrow 0x2 \cdot t_0 \oplus t_1$

Step 3. $y_0 \leftarrow SS_2(u_0), \quad y_1 \leftarrow SS_3(u_1)$, where $y = y_0|y_1, y_i \in \{0, 1\}^4$

The multiplication in $0x2 \cdot t_i$ is performed in $GF(2^4)$ defined by the lexicographically first primitive polynomial $z^4 + z + 1$. Figure 2 shows the construction of S_0 .

Table 1: S_0

	.0	.1	.2	.3	.4	.5	.6	.7	.8	.9	.a	.b	.c	.d	.e	.f
0.	57	49	d1	c6	2f	33	74	fb	95	6d	82	ea	0e	b0	a8	1c
1.	28	d0	4b	92	5c	ee	85	b1	c4	0a	76	3d	63	f9	17	af
2.	bf	a1	19	65	f7	7a	32	20	06	ce	e4	83	9d	5b	4c	d8
3.	42	5d	2e	e8	d4	9b	0f	13	3c	89	67	c0	71	aa	b6	f5
4.	a4	be	fd	8c	12	00	97	da	78	e1	cf	6b	39	43	55	26
5.	30	98	cc	dd	eb	54	b3	8f	4e	16	fa	22	a5	77	09	61
6.	d6	2a	53	37	45	c1	6c	ae	ef	70	08	99	8b	1d	f2	b4
7.	e9	c7	9f	4a	31	25	fe	7c	d3	a2	bd	56	14	88	60	0b
8.	cd	e2	34	50	9e	dc	11	05	2b	b7	a9	48	ff	66	8a	73
9.	03	75	86	f1	6a	a7	40	c2	b9	2c	db	1f	58	94	3e	ed
a.	fc	1b	a0	04	b8	8d	e6	59	62	93	35	7e	ca	21	df	47
b.	15	f3	ba	7f	a6	69	c8	4d	87	3b	9c	01	e0	de	24	52
c.	7b	0c	68	1e	80	b2	5a	e7	ad	d5	23	f4	46	3f	91	c9
d.	6e	84	72	bb	0d	18	d9	96	f0	5f	41	ac	27	c5	e3	3a
e.	81	6f	07	a3	79	f6	2d	38	1a	44	5e	b5	d2	ec	cb	90
f.	9a	36	e5	29	c3	4f	ab	64	51	f8	10	d7	bc	02	7d	8e

Table 2: S_1

	.0	.1	.2	.3	.4	.5	.6	.7	.8	.9	.a	.b	.c	.d	.e	.f
0.	6c	da	c3	e9	4e	9d	0a	3d	b8	36	b4	38	13	34	0c	d9
1.	bf	74	94	8f	b7	9c	e5	dc	9e	07	49	4f	98	2c	b0	93
2.	12	eb	cd	b3	92	e7	41	60	e3	21	27	3b	e6	19	d2	0e
3.	91	11	c7	3f	2a	8e	a1	bc	2b	c8	c5	0f	5b	f3	87	8b
4.	fb	f5	de	20	c6	a7	84	ce	d8	65	51	c9	a4	ef	43	53
5.	25	5d	9b	31	e8	3e	0d	d7	80	ff	69	8a	ba	0b	73	5c
6.	6e	54	15	62	f6	35	30	52	a3	16	d3	28	32	fa	aa	5e
7.	cf	ea	ed	78	33	58	09	7b	63	c0	c1	46	1e	df	a9	99
8.	55	04	c4	86	39	77	82	ec	40	18	90	97	59	dd	83	1f
9.	9a	37	06	24	64	7c	a5	56	48	08	85	d0	61	26	ca	6f
a.	7e	6a	b6	71	a0	70	05	d1	45	8c	23	1c	f0	ee	89	ad
b.	7a	4b	c2	2f	db	5a	4d	76	67	17	2d	f4	cb	b1	4a	a8
c.	b5	22	47	3a	d5	10	4c	72	cc	00	f9	e0	fd	e2	fe	ae
d.	f8	5f	ab	f1	1b	42	81	d6	be	44	29	a6	57	b9	af	f2
e.	d4	75	66	bb	68	9f	50	02	01	3c	7f	8d	1a	88	bd	ac
f.	f7	e4	79	96	a2	fc	6d	b2	6b	03	e1	2e	7d	14	95	1d

Table 3: Tables of SS_i ($0 \leq i < 4$)

x	0	1	2	3	4	5	6	7	8	9	a	b	c	d	e	f
$SS_0(x)$	e	6	c	a	8	7	2	f	b	1	4	0	5	9	d	3
$SS_1(x)$	6	4	0	d	2	b	a	3	9	c	e	f	8	7	5	1
$SS_2(x)$	b	8	5	e	a	6	4	c	f	7	2	3	1	0	d	9
$SS_3(x)$	a	2	6	d	3	4	5	e	0	7	8	9	b	f	c	1

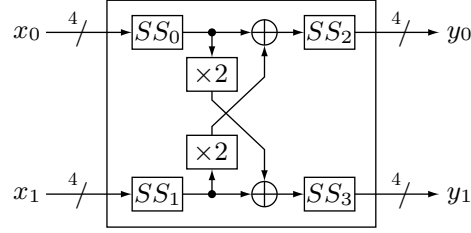

Figure 2: S_0

3.2.2 S_1

S_1 is defined as follows:

$$S_1 : \begin{cases} \{0, 1\}^8 & \rightarrow \{0, 1\}^8 \\ x_{(8)} & \mapsto y_{(8)} \end{cases}$$

$$y = \begin{cases} g(f(x)^{-1}) & \text{if } f(x) \neq 0 \\ g(0) & \text{if } f(x) = 0 \end{cases} .$$

The inverse function is performed in $\text{GF}(2^8)$ defined by a primitive polynomial $z^8 + z^4 + z^3 + z^2 + 1$. $f(\cdot)$ and $g(\cdot)$ are affine transformations over $\text{GF}(2)$, which are defined as follows.

$$f : \begin{cases} \{0, 1\}^8 & \rightarrow \{0, 1\}^8 \\ x_{(8)} & \mapsto y_{(8)} \end{cases}$$

$$\begin{pmatrix} y_0 \\ y_1 \\ y_2 \\ y_3 \\ y_4 \\ y_5 \\ y_6 \\ y_7 \end{pmatrix} = \begin{pmatrix} 0 & 0 & 0 & 1 & 1 & 0 & 0 & 0 \\ 0 & 1 & 0 & 1 & 0 & 0 & 0 & 1 \\ 0 & 0 & 0 & 0 & 0 & 0 & 0 & 1 \\ 0 & 0 & 0 & 0 & 0 & 1 & 1 & 0 \\ 0 & 1 & 1 & 0 & 0 & 1 & 0 & 1 \\ 0 & 1 & 0 & 1 & 1 & 1 & 0 & 0 \\ 0 & 1 & 1 & 0 & 0 & 0 & 0 & 0 \\ 1 & 0 & 0 & 0 & 0 & 0 & 0 & 1 \end{pmatrix} \begin{pmatrix} x_0 \\ x_1 \\ x_2 \\ x_3 \\ x_4 \\ x_5 \\ x_6 \\ x_7 \end{pmatrix} + \begin{pmatrix} 0 \\ 0 \\ 0 \\ 1 \\ 1 \\ 1 \\ 1 \\ 0 \end{pmatrix}$$

$$g : \begin{cases} \{0, 1\}^8 & \rightarrow \{0, 1\}^8 \\ x_{(8)} & \mapsto y_{(8)} \end{cases}$$

$$\begin{pmatrix} y_0 \\ y_1 \\ y_2 \\ y_3 \\ y_4 \\ y_5 \\ y_6 \\ y_7 \end{pmatrix} = \begin{pmatrix} 0 & 0 & 0 & 0 & 1 & 0 & 1 & 0 \\ 0 & 1 & 0 & 0 & 0 & 0 & 0 & 1 \\ 0 & 1 & 0 & 1 & 1 & 0 & 0 & 0 \\ 0 & 0 & 1 & 0 & 0 & 0 & 0 & 0 \\ 0 & 0 & 1 & 1 & 0 & 0 & 0 & 0 \\ 0 & 0 & 0 & 0 & 0 & 0 & 1 & 0 \\ 1 & 0 & 0 & 1 & 0 & 0 & 0 & 0 \\ 0 & 1 & 0 & 0 & 0 & 1 & 0 & 0 \end{pmatrix} \begin{pmatrix} x_0 \\ x_1 \\ x_2 \\ x_3 \\ x_4 \\ x_5 \\ x_6 \\ x_7 \end{pmatrix} + \begin{pmatrix} 0 \\ 1 \\ 1 \\ 0 \\ 1 \\ 0 \\ 0 \\ 1 \end{pmatrix}$$

Here, $x = x_0|x_1|x_2|x_3|x_4|x_5|x_6|x_7$ and $y = y_0|y_1|y_2|y_3|y_4|y_5|y_6|y_7$, $x_i, y_i \in \{0, 1\}$. The constants in f and g can be represented as $0x1e$ and $0x69$, respectively.

3.3 Diffusion Matrices

Two matrices M_0 and M_1 are defined as follows.

$$M_0 = \begin{pmatrix} 0x01 & 0x02 & 0x04 & 0x06 \\ 0x02 & 0x01 & 0x06 & 0x04 \\ 0x04 & 0x06 & 0x01 & 0x02 \\ 0x06 & 0x04 & 0x02 & 0x01 \end{pmatrix}, \quad M_1 = \begin{pmatrix} 0x01 & 0x08 & 0x02 & 0x0a \\ 0x08 & 0x01 & 0x0a & 0x02 \\ 0x02 & 0x0a & 0x01 & 0x08 \\ 0x0a & 0x02 & 0x08 & 0x01 \end{pmatrix}.$$

The multiplications of a matrix and a vector are performed in GF(2⁸) defined by the lexicographically first primitive polynomial $z^8 + z^4 + z^3 + z^2 + 1$.

4 Data Processing Part

4.1 Overall Structure

The data processing part of CLEFIA consists of ENC_r for encryption and DEC_r for decryption. ENC_r and DEC_r are based on the 4-branch generalized Feistel structure $GFN_{4,r}$. Let $P, C \in \{0, 1\}^{128}$ be a plaintext and a ciphertext, and let $P_i, C_i \in \{0, 1\}^{32}$ ($0 \leq i < 4$) be divided plaintext and ciphertext where $P = P_0|P_1|P_2|P_3$ and $C = C_0|C_1|C_2|C_3$, and let $WK_0, WK_1, WK_2, WK_3 \in \{0, 1\}^{32}$ be whitening keys and $RK_i \in \{0, 1\}^{32}$ ($0 \leq i < 2r$) be round keys provided by the key scheduling part. Then, r -round encryption function ENC_r is defined as follows:

$$ENC_r : \begin{cases} \{\{0, 1\}^{32}\}^4 \times \{\{0, 1\}^{32}\}^{2r} \times \{\{0, 1\}^{32}\}^4 \rightarrow \{\{0, 1\}^{32}\}^4 \\ (WK_{0(32)}, \dots, WK_{3(32)}, RK_{0(32)}, \dots, RK_{2r-1(32)}, P_{0(32)}, \dots, P_{3(32)}) \\ \mapsto C_{0(32)}, \dots, C_{3(32)} \end{cases}$$

$Step\ 1.$ $T_0 T_1 T_2 T_3 \leftarrow P_0 (P_1 \oplus WK_0) P_2 (P_3 \oplus WK_1)$
$Step\ 2.$ $T_0 T_1 T_2 T_3 \leftarrow GFN_{4,r}(RK_0, \dots, RK_{2r-1}, T_0, T_1, T_2, T_3)$
$Step\ 3.$ $C_0 C_1 C_2 C_3 \leftarrow T_0 (T_1 \oplus WK_2) T_2 (T_3 \oplus WK_3)$

The decryption function DEC_r is defined as follows:

$$DEC_r : \begin{cases} \{\{0, 1\}^{32}\}^4 \times \{\{0, 1\}^{32}\}^{2r} \times \{\{0, 1\}^{32}\}^4 \rightarrow \{\{0, 1\}^{32}\}^4 \\ (WK_{0(32)}, \dots, WK_{3(32)}, RK_{0(32)}, \dots, RK_{2r-1(32)}, C_{0(32)}, \dots, C_{3(32)}) \\ \mapsto P_{0(32)}, \dots, P_{3(32)} \end{cases}$$

$Step\ 1.$ $T_0 T_1 T_2 T_3 \leftarrow C_0 (C_1 \oplus WK_2) C_2 (C_3 \oplus WK_3)$
$Step\ 2.$ $T_0 T_1 T_2 T_3 \leftarrow GFN_{4,r}^{-1}(RK_0, \dots, RK_{2r-1}, T_0, T_1, T_2, T_3)$
$Step\ 3.$ $C_0 C_1 C_2 C_3 \leftarrow T_0 (T_1 \oplus WK_0) T_2 (T_3 \oplus WK_1)$

Figure 3 illustrates both of ENC_r and DEC_r .

4.2 The Numbers of Rounds

The number of rounds, r , is 18, 22 and 26 for 128-bit, 192-bit and 256-bit keys, respectively. The total number of RK_i depends on the key length. The data processing part requires 36, 44 and 52 round keys for 128-bit, 192-bit and 256-bit keys, respectively.

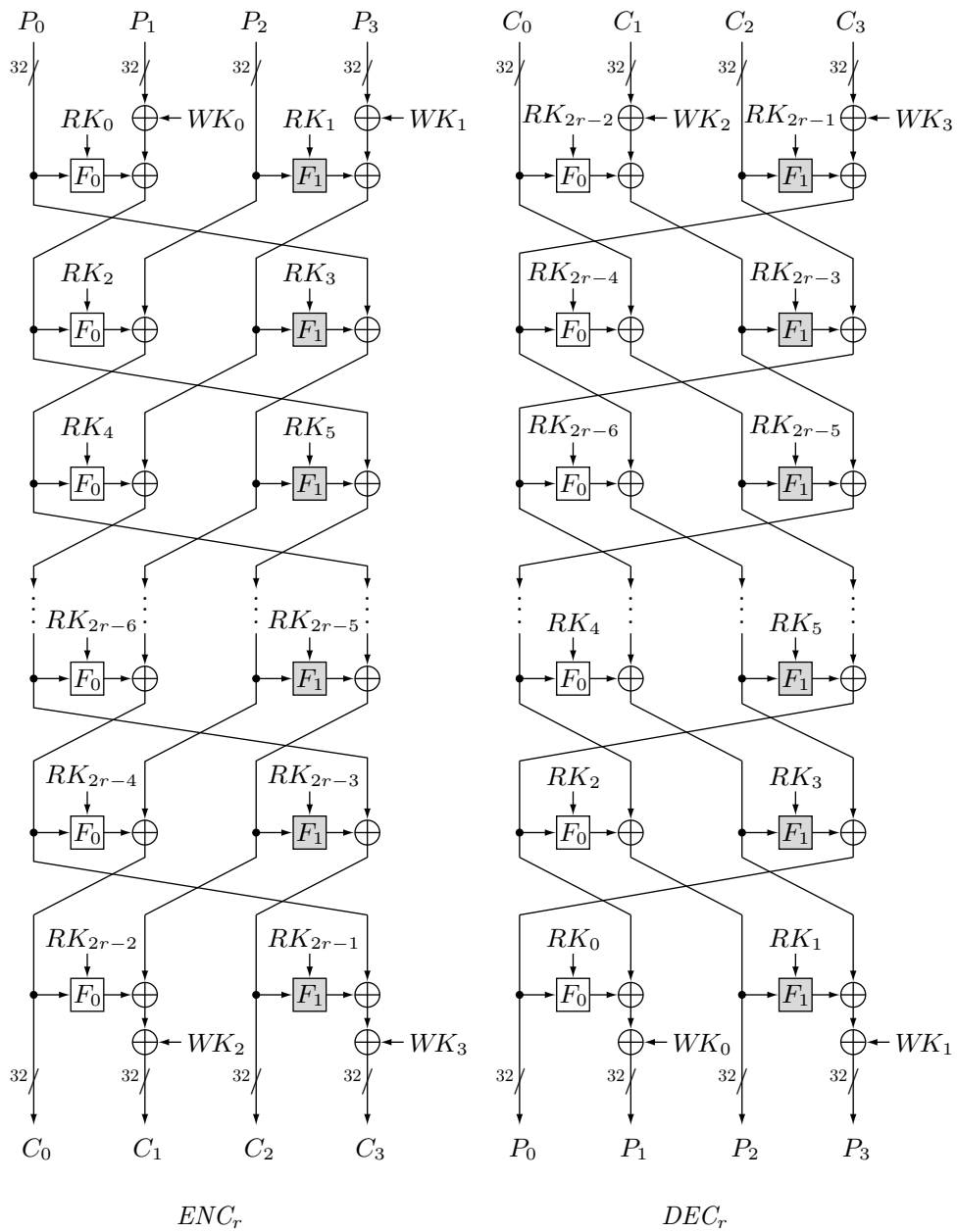

Figure 3: Structures of Data Processing Part

5 Key Scheduling Part

The key scheduling part of CLEFIA supports 128, 192 and 256-bit keys and outputs whitening keys WK_i ($0 \leq i < 4$) and round keys RK_j ($0 \leq j < 2r$) for the data processing part. We first define the *DoubleSwap* function which is used in the key scheduling part.

Definition 1 *The DoubleSwap Function Σ*

The DoubleSwap function $\Sigma : \{0, 1\}^{128} \rightarrow \{0, 1\}^{128}$ is defined as follows:

$$X_{(128)} \mapsto Y_{(128)} \\ Y = X[7 - 63] \mid X[121 - 127] \mid X[0 - 6] \mid X[64 - 120] ,$$

where $X[a - b]$ denotes a bit string cut from the a -th bit to the b -th bit of X . 0-th bit is the most significant bit.

The DoubleSwap function is illustrated in Fig 4.

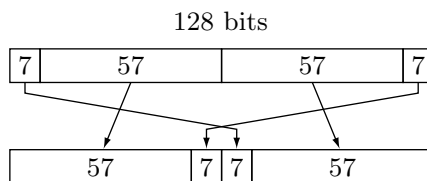

Figure 4: DoubleSwap Function Σ

5.1 Overall Structure

The key scheduling part of CLEFIA provides whitening keys and round keys for the data processing part. Let K be the key and L be an intermediate key, and the key scheduling part consists of the following two steps.

1. Generating L from K .
2. Expanding K and L (Generating WK_i and RK_j).

To generate L from K , the key schedule for a 128-bit key uses a 128-bit permutation $GFN_{4,12}$, while the key schedules for 192/256-bit keys use a 256-bit permutation $GFN_{8,10}$.

5.2 Key Scheduling for a 128-bit Key

The 128-bit intermediate key L is generated by applying $GFN_{4,12}$ which takes twenty-four 32-bit constant values $CON_i^{(128)}$ ($0 \leq i < 24$) as round

keys and $K = K_0|K_1|K_2|K_3$ as an input. Then K and L are used to generate WK_i ($0 \leq i < 4$) and RK_j ($0 \leq j < 36$) in the following steps. In the latter part, thirty-six 32-bit constant values $CON_i^{(128)}$ ($24 \leq i < 60$) are used. The generation steps of $CON_i^{(128)}$ are explained in Sect 5.5.

(Generating L from K)	
<i>Step 1.</i> $L \leftarrow GFN_{4,12}(CON_0^{(128)}, \dots, CON_{23}^{(128)}, K_0, \dots, K_3)$	
(Expanding K and L)	
<i>Step 2.</i> $WK_0 WK_1 WK_2 WK_3 \leftarrow K$	
<i>Step 3.</i> For $i = 0$ to 8 do the following:	
$T \leftarrow L \oplus (CON_{24+4i}^{(128)} CON_{24+4i+1}^{(128)} CON_{24+4i+2}^{(128)} CON_{24+4i+3}^{(128)})$	
$L \leftarrow \Sigma(L)$	
if i is odd: $T \leftarrow T \oplus K$	
$RK_{4i} RK_{4i+1} RK_{4i+2} RK_{4i+3} \leftarrow T$	

Figure 5 shows the relationship between generated round keys and related data.

WK_0	WK_1	WK_2	WK_3	$\leftarrow K$	
RK_0	RK_1	RK_2	RK_3	$\leftarrow L \oplus (CON_{24}^{(128)} CON_{25}^{(128)} CON_{26}^{(128)} CON_{27}^{(128)})$	
RK_4	RK_5	RK_6	RK_7	$\leftarrow \Sigma(L) \oplus K \oplus (CON_{28}^{(128)} CON_{29}^{(128)} CON_{30}^{(128)} CON_{31}^{(128)})$	
RK_8	RK_9	RK_{10}	RK_{11}	$\leftarrow \Sigma^2(L) \oplus (CON_{32}^{(128)} CON_{33}^{(128)} CON_{34}^{(128)} CON_{35}^{(128)})$	
RK_{12}	RK_{13}	RK_{14}	RK_{15}	$\leftarrow \Sigma^3(L) \oplus K \oplus (CON_{36}^{(128)} CON_{37}^{(128)} CON_{38}^{(128)} CON_{39}^{(128)})$	
RK_{16}	RK_{17}	RK_{18}	RK_{19}	$\leftarrow \Sigma^4(L) \oplus (CON_{40}^{(128)} CON_{41}^{(128)} CON_{42}^{(128)} CON_{43}^{(128)})$	
RK_{20}	RK_{21}	RK_{22}	RK_{23}	$\leftarrow \Sigma^5(L) \oplus K \oplus (CON_{44}^{(128)} CON_{45}^{(128)} CON_{46}^{(128)} CON_{47}^{(128)})$	
RK_{24}	RK_{25}	RK_{26}	RK_{27}	$\leftarrow \Sigma^6(L) \oplus (CON_{48}^{(128)} CON_{49}^{(128)} CON_{50}^{(128)} CON_{51}^{(128)})$	
RK_{28}	RK_{29}	RK_{30}	RK_{31}	$\leftarrow \Sigma^7(L) \oplus K \oplus (CON_{52}^{(128)} CON_{53}^{(128)} CON_{54}^{(128)} CON_{55}^{(128)})$	
RK_{32}	RK_{33}	RK_{34}	RK_{35}	$\leftarrow \Sigma^8(L) \oplus (CON_{56}^{(128)} CON_{57}^{(128)} CON_{58}^{(128)} CON_{59}^{(128)})$	

Figure 5: Expanding K and L (128-bit key)

5.3 Key Scheduling for a 192-bit Key

Two 128-bit values K_L, K_R are generated from a 192-bit key $K = K_0|K_1|K_2|K_3|K_4|K_5$, $K_i \in \{0, 1\}^{32}$. Then two 128-bit values L_L, L_R are generated by applying $GFN_{8,10}$ which takes $CON_i^{(192)}$ ($0 \leq i < 40$) as round keys and $K_L|K_R$ as a 256-bit input. Figure 6 shows the construction of $GFN_{8,10}$.

Then K_L, K_R and L_L, L_R are used to generate WK_i ($0 \leq i < 4$) and RK_j ($0 \leq j < 44$) in the following steps. In the latter part, forty-four 32-bit constant values $CON_i^{(192)}$ ($40 \leq i < 84$) are used.

The following steps show the 192-bit/256-bit key scheduling. For the 192-bit key scheduling, the value of k is set as 192.

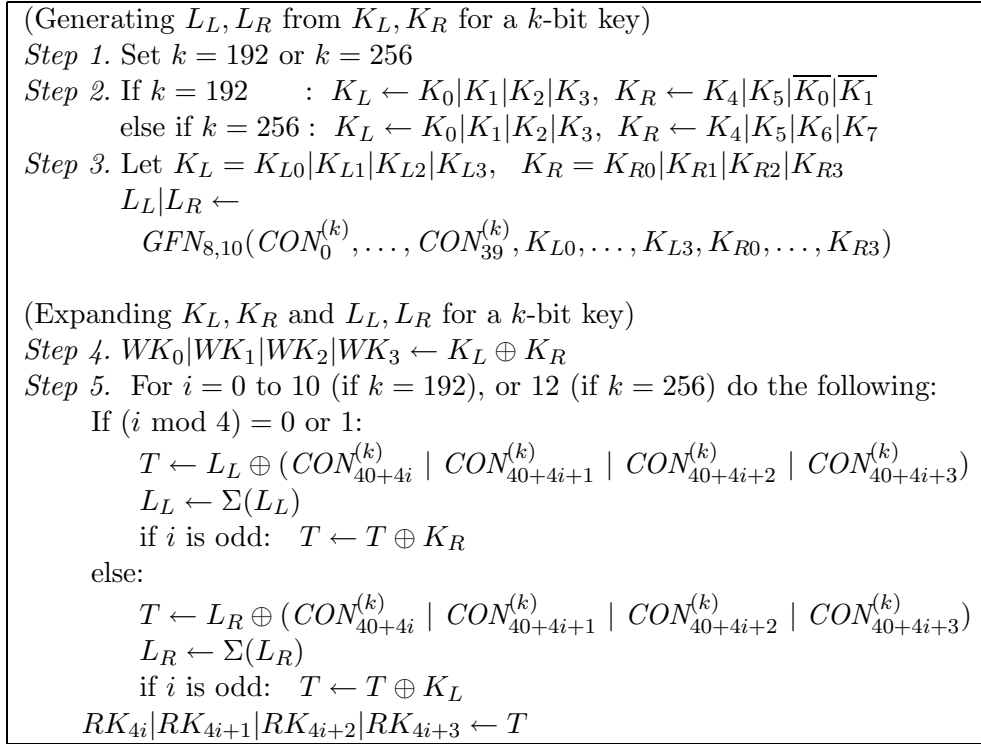

Figure 7 shows the relationship between generated round keys and related data.

5.4 Key Scheduling for a 256-bit Key

The key scheduling for a 256-bit key is almost the same as that for 192-bit key, except for constant values, required number of RK_i , and initialization of K_R .

For a 256-bit key, the value of k is set as 256, and the steps are almost the same as in the 192-bit key case. The difference is that we use $CON_i^{(256)}$ ($0 \leq i < 40$) as round keys to generate L_L and L_R , and then to generate RK_j ($0 \leq j < 52$), we use fifty-two 32-bit constant values $CON_i^{(256)}$ ($40 \leq i < 92$).

Figure 8 shows the relationship between generated round keys and related data.

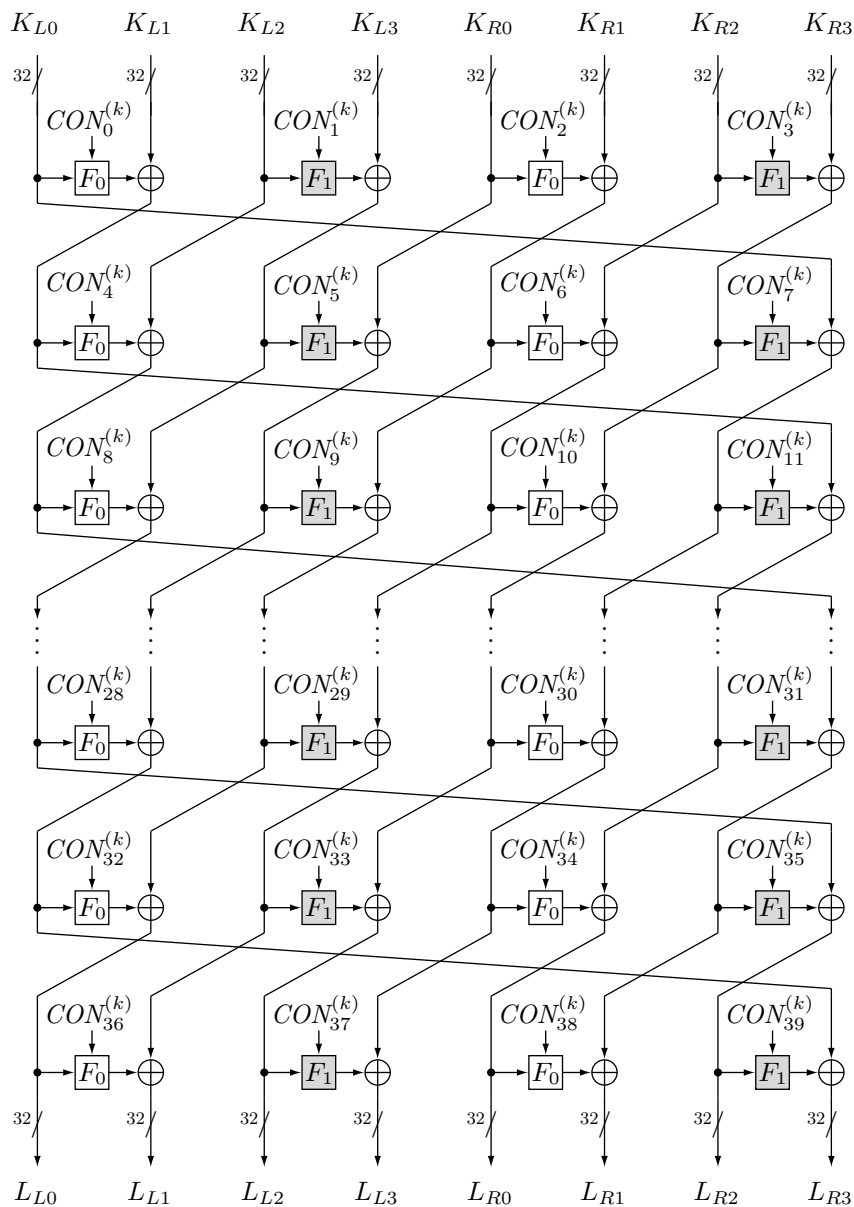

Figure 6: Structure of $GFN_{8,10}$

WK_0	WK_1	WK_2	WK_3	$\leftarrow K_L \oplus K_R$				
RK_0	RK_1	RK_2	RK_3	$\leftarrow L_L \oplus$	$(CON_{40}^{(192)})$	$ CON_{41}^{(192)}$	$ CON_{42}^{(192)}$	$ CON_{43}^{(192)}$
RK_4	RK_5	RK_6	RK_7	$\leftarrow \Sigma(L_L) \oplus K_R \oplus$	$(CON_{44}^{(192)})$	$ CON_{45}^{(192)}$	$ CON_{46}^{(192)}$	$ CON_{47}^{(192)}$
RK_8	RK_9	RK_{10}	RK_{11}	$\leftarrow L_R \oplus$	$(CON_{48}^{(192)})$	$ CON_{49}^{(192)}$	$ CON_{50}^{(192)}$	$ CON_{51}^{(192)}$
RK_{12}	RK_{13}	RK_{14}	RK_{15}	$\leftarrow \Sigma(L_R) \oplus K_L \oplus$	$(CON_{52}^{(192)})$	$ CON_{53}^{(192)}$	$ CON_{54}^{(192)}$	$ CON_{55}^{(192)}$
RK_{16}	RK_{17}	RK_{18}	RK_{19}	$\leftarrow \Sigma^2(L_L) \oplus$	$(CON_{56}^{(192)})$	$ CON_{57}^{(192)}$	$ CON_{58}^{(192)}$	$ CON_{59}^{(192)}$
RK_{20}	RK_{21}	RK_{22}	RK_{23}	$\leftarrow \Sigma^3(L_L) \oplus K_R \oplus$	$(CON_{60}^{(192)})$	$ CON_{61}^{(192)}$	$ CON_{62}^{(192)}$	$ CON_{63}^{(192)}$
RK_{24}	RK_{25}	RK_{26}	RK_{27}	$\leftarrow \Sigma^2(L_R) \oplus$	$(CON_{64}^{(192)})$	$ CON_{65}^{(192)}$	$ CON_{66}^{(192)}$	$ CON_{67}^{(192)}$
RK_{28}	RK_{29}	RK_{30}	RK_{31}	$\leftarrow \Sigma^3(L_R) \oplus K_L \oplus$	$(CON_{68}^{(192)})$	$ CON_{69}^{(192)}$	$ CON_{70}^{(192)}$	$ CON_{71}^{(192)}$
RK_{32}	RK_{33}	RK_{34}	RK_{35}	$\leftarrow \Sigma^4(L_L) \oplus$	$(CON_{72}^{(192)})$	$ CON_{73}^{(192)}$	$ CON_{74}^{(192)}$	$ CON_{75}^{(192)}$
RK_{36}	RK_{37}	RK_{38}	RK_{39}	$\leftarrow \Sigma^5(L_L) \oplus K_R \oplus$	$(CON_{76}^{(192)})$	$ CON_{77}^{(192)}$	$ CON_{78}^{(192)}$	$ CON_{79}^{(192)}$
RK_{40}	RK_{41}	RK_{42}	RK_{43}	$\leftarrow \Sigma^4(L_R) \oplus$	$(CON_{80}^{(192)})$	$ CON_{81}^{(192)}$	$ CON_{82}^{(192)}$	$ CON_{83}^{(192)}$

 Figure 7: Expanding K_L , K_R , L_L and L_R (192-bit key)

WK_0	WK_1	WK_2	WK_3	$\leftarrow K_L \oplus K_R$				
RK_0	RK_1	RK_2	RK_3	$\leftarrow L_L \oplus$	$(CON_{40}^{(256)})$	$ CON_{41}^{(256)}$	$ CON_{42}^{(256)}$	$ CON_{43}^{(256)}$
RK_4	RK_5	RK_6	RK_7	$\leftarrow \Sigma(L_L) \oplus K_R \oplus$	$(CON_{44}^{(256)})$	$ CON_{45}^{(256)}$	$ CON_{46}^{(256)}$	$ CON_{47}^{(256)}$
RK_8	RK_9	RK_{10}	RK_{11}	$\leftarrow L_R \oplus$	$(CON_{48}^{(256)})$	$ CON_{49}^{(256)}$	$ CON_{50}^{(256)}$	$ CON_{51}^{(256)}$
RK_{12}	RK_{13}	RK_{14}	RK_{15}	$\leftarrow \Sigma(L_R) \oplus K_L \oplus$	$(CON_{52}^{(256)})$	$ CON_{53}^{(256)}$	$ CON_{54}^{(256)}$	$ CON_{55}^{(256)}$
RK_{16}	RK_{17}	RK_{18}	RK_{19}	$\leftarrow \Sigma^2(L_L) \oplus$	$(CON_{56}^{(256)})$	$ CON_{57}^{(256)}$	$ CON_{58}^{(256)}$	$ CON_{59}^{(256)}$
RK_{20}	RK_{21}	RK_{22}	RK_{23}	$\leftarrow \Sigma^3(L_L) \oplus K_R \oplus$	$(CON_{60}^{(256)})$	$ CON_{61}^{(256)}$	$ CON_{62}^{(256)}$	$ CON_{63}^{(256)}$
RK_{24}	RK_{25}	RK_{26}	RK_{27}	$\leftarrow \Sigma^2(L_R) \oplus$	$(CON_{64}^{(256)})$	$ CON_{65}^{(256)}$	$ CON_{66}^{(256)}$	$ CON_{67}^{(256)}$
RK_{28}	RK_{29}	RK_{30}	RK_{31}	$\leftarrow \Sigma^3(L_R) \oplus K_L \oplus$	$(CON_{68}^{(256)})$	$ CON_{69}^{(256)}$	$ CON_{70}^{(256)}$	$ CON_{71}^{(256)}$
RK_{32}	RK_{33}	RK_{34}	RK_{35}	$\leftarrow \Sigma^4(L_L) \oplus$	$(CON_{72}^{(256)})$	$ CON_{73}^{(256)}$	$ CON_{74}^{(256)}$	$ CON_{75}^{(256)}$
RK_{36}	RK_{37}	RK_{38}	RK_{39}	$\leftarrow \Sigma^5(L_L) \oplus K_R \oplus$	$(CON_{76}^{(256)})$	$ CON_{77}^{(256)}$	$ CON_{78}^{(256)}$	$ CON_{79}^{(256)}$
RK_{40}	RK_{41}	RK_{42}	RK_{43}	$\leftarrow \Sigma^4(L_R) \oplus$	$(CON_{80}^{(256)})$	$ CON_{81}^{(256)}$	$ CON_{82}^{(256)}$	$ CON_{83}^{(256)}$
RK_{44}	RK_{45}	RK_{46}	RK_{47}	$\leftarrow \Sigma^5(L_R) \oplus K_L \oplus$	$(CON_{84}^{(256)})$	$ CON_{85}^{(256)}$	$ CON_{86}^{(256)}$	$ CON_{87}^{(256)}$
RK_{48}	RK_{49}	RK_{50}	RK_{51}	$\leftarrow \Sigma^6(L_L) \oplus$	$(CON_{88}^{(256)})$	$ CON_{89}^{(256)}$	$ CON_{90}^{(256)}$	$ CON_{91}^{(256)}$

 Figure 8: Expanding K_L , K_R , L_L and L_R (256-bit key)

5.5 Constant Values

32-bit constant values $CON_i^{(k)}$ are used in the key scheduling algorithm. We need 60, 84 and 92 constant values for 128, 192 and 256-bit keys, respectively. Let $\mathbf{P}_{(16)} = \mathbf{0xb7e1}$ ($= (e-2) \cdot 2^{16}$) and $\mathbf{Q}_{(16)} = \mathbf{0x243f}$ ($= (\pi-3) \cdot 2^{16}$), where e is the base of the natural logarithm (2.71828...) and π is the circle ratio (3.14159...). $CON_i^{(k)}$, for $k = 128, 192, 256$, are generated by the following way (See Table 4 for the repetition numbers $l^{(k)}$ and the initial values $IV^{(k)}$).

Step 1. $T_0 \leftarrow IV^{(k)}$
Step 2. For $i = 0$ to $l^{(k)} - 1$ do the following:
Step 2.1. $CON_{2i}^{(k)} \leftarrow (T_i \oplus \mathbf{P}) \mid (\overline{T_i} \lll 1)$
Step 2.2. $CON_{2i+1}^{(k)} \leftarrow (\overline{T_i} \oplus \mathbf{Q}) \mid (T_i \lll 8)$
Step 2.3. $T_{i+1} \leftarrow T_i \cdot \mathbf{0x0002}^{-1}$

In Step 2.3, the multiplications are performed in the field $GF(2^{16})$ defined by a primitive polynomial $z^{16} + z^{15} + z^{13} + z^{11} + z^5 + z^4 + 1$ ($=\mathbf{0x1a831}$)⁵.

Table 4: Required Numbers of Constant Values

k	# of $CON_i^{(k)}$	$l^{(k)}$	$IV^{(k)}$
128	60	30	$\mathbf{0x428a}$ ($= (\sqrt[3]{2} - 1) \cdot 2^{16}$)
192	84	42	$\mathbf{0x7137}$ ($= (\sqrt[3]{3} - 1) \cdot 2^{16}$)
256	92	46	$\mathbf{0xb5c0}$ ($= (\sqrt[3]{5} - 1) \cdot 2^{16}$)

Tables 5-7 show the values of T_i , and Tables 8-12 show the values of $CON_i^{(k)}$.

⁵The lower 16-bit value is defined as $\mathbf{0xa831} = (\sqrt[3]{101} - 4) \cdot 2^{16}$. ‘101’ is the smallest prime number satisfying the primitive polynomial condition in this form.

Table 5: $T_i^{(128)}$

i	0	1	2	3	4	5	6	7
$T_i^{(128)}$	428a	2145	c4ba	625d	e536	729b	ed55	a2b2
i	8	9	10	11	12	13	14	15
$T_i^{(128)}$	5159	fc4b	7e5a	3f2d	cb8e	65c7	e6fb	a765
i	16	17	18	19	20	21	22	23
$T_i^{(128)}$	87aa	43d5	f5f2	7af9	e964	74b2	3a59	c934
i	24	25	26	27	28	29		
$T_i^{(128)}$	649a	324d	cd3e	669f	e757	a7b3		

Table 6: $T_i^{(192)}$

i	0	1	2	3	4	5	6	7
$T_i^{(192)}$	7137	ec83	a259	8534	429a	214d	c4be	625f
i	8	9	10	11	12	13	14	15
$T_i^{(192)}$	e537	a683	8759	97b4	4bda	25ed	c6ee	6377
i	16	17	18	19	20	21	22	23
$T_i^{(192)}$	e5a3	a6c9	877c	43be	21df	c4f7	b663	8f29
i	24	25	26	27	28	29	30	31
$T_i^{(192)}$	938c	49c6	24e3	c669	b72c	5b96	2dcb	c2fd
i	32	33	34	35	36	37	38	39
$T_i^{(192)}$	b566	5ab3	f941	a8b8	545c	2a2e	1517	de93
i	40	41						
$T_i^{(192)}$	bb51	89b0						

Table 7: $T_i^{(256)}$

i	0	1	2	3	4	5	6	7
$T_i^{(256)}$	b5c0	5ae0	2d70	16b8	0b5c	05ae	02d7	d573
i	8	9	10	11	12	13	14	15
$T_i^{(256)}$	bea1	8b48	45a4	22d2	1169	dcac	6e56	372b
i	16	17	18	19	20	21	22	23
$T_i^{(256)}$	cf8d	b3de	59ef	f8ef	a86f	802f	940f	9e1f
i	24	25	26	27	28	29	30	31
$T_i^{(256)}$	9b17	9993	98d1	9870	4c38	261c	130e	0987
i	32	33	34	35	36	37	38	39
$T_i^{(256)}$	d0db	bc75	8a22	4511	f690	7b48	3da4	1ed2
i	40	41	42	43	44	45		
$T_i^{(256)}$	0f69	d3ac	69d6	34eb	ce6d	b32e		

Table 8: $CON_i^{(128)}$ ($0 \leq i < 60$)

i	0	1	2	3
$CON_i^{(128)}$	f56b7aeb	994a8a42	96a4bd75	fa854521
i	4	5	6	7
$CON_i^{(128)}$	735b768a	1f7abac4	d5bc3b45	b99d5d62
i	8	9	10	11
$CON_i^{(128)}$	52d73592	3ef636e5	c57a1ac9	a95b9b72
i	12	13	14	15
$CON_i^{(128)}$	5ab42554	369555ed	1553ba9a	7972b2a2
i	16	17	18	19
$CON_i^{(128)}$	e6b85d4d	8a995951	4b550696	2774b4fc
i	20	21	22	23
$CON_i^{(128)}$	c9bb034b	a59a5a7e	88cc81a5	e4ed2d3f
i	24	25	26	27
$CON_i^{(128)}$	7c6f68e2	104e8ecb	d2263471	be07c765
i	28	29	30	31
$CON_i^{(128)}$	511a3208	3d3bfbe6	1084b134	7ca565a7
i	32	33	34	35
$CON_i^{(128)}$	304bf0aa	5c6aaa87	f4347855	9815d543
i	36	37	38	39
$CON_i^{(128)}$	4213141a	2e32f2f5	cd180a0d	a139f97a
i	40	41	42	43
$CON_i^{(128)}$	5e852d36	32a464e9	c353169b	af72b274
i	44	45	46	47
$CON_i^{(128)}$	8db88b4d	e199593a	7ed56d96	12f434c9
i	48	49	50	51
$CON_i^{(128)}$	d37b36cb	bf5a9a64	85ac9b65	e98d4d32
i	52	53	54	55
$CON_i^{(128)}$	7adf6582	16fe3ecd	d17e32c1	bd5f9f66
i	56	57	58	59
$CON_i^{(128)}$	50b63150	3c9757e7	1052b098	7c73b3a7

Table 9: $CON_i^{(192)}$ ($0 \leq i < 60$)

i	0	1	2	3
$CON_i^{(192)}$	c6d61d91	aaf73771	5b6226f8	374383ec
i	4	5	6	7
$CON_i^{(192)}$	15b8bb4c	799959a2	32d5f596	5ef43485
i	8	9	10	11
$CON_i^{(192)}$	f57b7acb	995a9a42	96acbd65	fa8d4d21
i	12	13	14	15
$CON_i^{(192)}$	735f7682	1f7ebec4	d5be3b41	b99f5f62
i	16	17	18	19
$CON_i^{(192)}$	52d63590	3ef737e5	1162b2f8	7d4383a6
i	20	21	22	23
$CON_i^{(192)}$	30b8f14c	5c995987	2055d096	4c74b497
i	24	25	26	27
$CON_i^{(192)}$	fc3b684b	901ada4b	920cb425	fe2ded25
i	28	29	30	31
$CON_i^{(192)}$	710f7222	1d2eeec6	d4963911	b8b77763
i	32	33	34	35
$CON_i^{(192)}$	524234b8	3e63a3e5	1128b26c	7d09c9a6
i	36	37	38	39
$CON_i^{(192)}$	309df106	5cbc7c87	f45f7883	987ebe43
i	40	41	42	43
$CON_i^{(192)}$	963ebc41	fa1fdf21	73167610	1f37f7c4
i	44	45	46	47
$CON_i^{(192)}$	01829338	6da363b6	38c8e1ac	54e9298f
i	48	49	50	51
$CON_i^{(192)}$	246dd8e6	484c8c93	fe276c73	9206c649
i	52	53	54	55
$CON_i^{(192)}$	9302b639	ff23e324	7188732c	1da969c6
i	56	57	58	59
$CON_i^{(192)}$	00cd91a6	6cec2cb7	ec7748d3	8056965b

Table 10: $CON_i^{(192)}$ ($60 \leq i < 84$)

i	60	61	62	63
$CON_i^{(192)}$	9a2aa469	f60bcb2d	751c7a04	193dfdc2
i	64	65	66	67
$CON_i^{(192)}$	02879532	6ea666b5	ed524a99	8173b35a
i	68	69	70	71
$CON_i^{(192)}$	4ea00d7c	228141f9	1f59ae8e	7378b8a8
i	72	73	74	75
$CON_i^{(192)}$	e3bd5747	8f9c5c54	9dcfaba3	f1ee2e2a
i	76	77	78	79
$CON_i^{(192)}$	a2f6d5d1	ced71715	697242d8	055393de
i	80	81	82	83
$CON_i^{(192)}$	0cb0895c	609151bb	3e51ec9e	5270b089

Table 11: $CON_i^{(256)}$ ($0 \leq i < 24$)

i	0	1	2	3
$CON_i^{(256)}$	0221947e	6e00c0b5	ed014a3f	8120e05a
i	4	5	6	7
$CON_i^{(256)}$	9a91a51f	f6b0702d	a159d28f	cd78b816
i	8	9	10	11
$CON_i^{(256)}$	bcbde947	d09c5c0b	b24ff4a3	de6eae05
i	12	13	14	15
$CON_i^{(256)}$	b536fa51	d917d702	62925518	0eb373d5
i	16	17	18	19
$CON_i^{(256)}$	094082bc	6561a1be	3ca9e96e	5088488b
i	20	21	22	23
$CON_i^{(256)}$	f24574b7	9e64a445	9533ba5b	f912d222

Table 12: $CON_i^{(256)}$ ($24 \leq i < 92$)

i	24	25	26	27
$CON_i^{(256)}$	a688dd2d	caa96911	6b4d46a6	076cacdc
i	28	29	30	31
$CON_i^{(256)}$	d9b72353	b596566e	80ca91a9	eceb2b37
i	32	33	34	35
$CON_i^{(256)}$	786c60e4	144d8dcf	043f9842	681edeb3
i	36	37	38	39
$CON_i^{(256)}$	ee0e4c21	822fef59	4f0e0e20	232feff8
i	40	41	42	43
$CON_i^{(256)}$	1f8eaf20	73af6fa8	37ceffa0	5bef2f80
i	44	45	46	47
$CON_i^{(256)}$	23eed7e0	4fcf0f94	29fec3c0	45df1f9e
i	48	49	50	51
$CON_i^{(256)}$	2cf6c9d0	40d7179b	2e72ccd8	42539399
i	52	53	54	55
$CON_i^{(256)}$	2f30ce5c	4311d198	2f91cf1e	43b07098
i	56	57	58	59
$CON_i^{(256)}$	fb9678f	97f8384c	91fdb3c7	fddc1c26
i	60	61	62	63
$CON_i^{(256)}$	a4efd9e3	c8ce0e13	be66ecf1	d2478709
i	64	65	66	67
$CON_i^{(256)}$	673a5e48	0b1bdbd0	0b948714	67b575bc
i	68	69	70	71
$CON_i^{(256)}$	3dc3ebba	51e2228a	f2f075dd	9ed11145
i	72	73	74	75
$CON_i^{(256)}$	417112de	2d5090f6	cca9096f	a088487b
i	76	77	78	79
$CON_i^{(256)}$	8a4584b7	e664a43d	a933c25b	c512d21e
i	80	81	82	83
$CON_i^{(256)}$	b888e12d	d4a9690f	644d58a6	086cacd3
i	84	85	86	87
$CON_i^{(256)}$	de372c53	b216d669	830a9629	ef2beb34
i	88	89	90	91
$CON_i^{(256)}$	798c6324	15ad6dce	04cf99a2	68ee2eb3

6 Test Vectors

We give test vectors of CLEFIA for each key length. The data are expressed in hexadecimal form.

128-bit key:

key	ffeeddcc	bbaa9988	77665544	33221100
plaintext	00010203	04050607	08090a0b	0c0d0e0f
ciphertext	de2bf2fd	9b74aacd	f1298555	459494fd

192-bit key:

key	ffeeddcc	bbaa9988	77665544	33221100	f0e0d0c0	b0a09080
plaintext	00010203	04050607	08090a0b	0c0d0e0f		
ciphertext	e2482f64	9f028dc4	80dda184	fde181ad		

256-bit key:

key	ffeeddcc	bbaa9988	77665544	33221100	f0e0d0c0	b0a09080	70605040	30201000
plaintext	00010203	04050607	08090a0b	0c0d0e0f				
ciphertext	a1397814	289de80c	10da46d1	fa48b38a				

6.1 Test Vectors (Intermediate Values)

128-bit key:

key	ffeeddcc	bbaa9988	77665544	33221100
plaintext	00010203	04050607	08090a0b	0c0d0e0f
ciphertext	de2bf2fd	9b74aacd	f1298555	459494fd
<i>L</i>	8f89a61b	9db9d0f3	93e65627	da0d027e
<i>WK</i> _{0,1,2,3}	ffeeddcc	bbaa9988	77665544	33221100
<i>RK</i> _{0,1,2,3}	f3e6cef9	8df75e38	41c06256	640ac51b
<i>RK</i> _{4,5,6,7}	6a27e20a	5a791b90	e8c528dc	00336ea3
<i>RK</i> _{8,9,10,11}	59cd17c4	28565583	312a37cc	c08abd77
<i>RK</i> _{12,13,14,15}	7e8e7eec	8be7e949	d3f463d6	a0aad6aa
<i>RK</i> _{16,17,18,19}	e75eb039	0d657eb9	018002e2	9117d009
<i>RK</i> _{20,21,22,23}	9f98d11e	babee8cf	b0369efa	d3aaef0d
<i>RK</i> _{24,25,26,27}	3438f93b	f9cea4a0	68df9029	b869b4a7
<i>RK</i> _{28,29,30,31}	24d6406d	e74bc550	41c28193	16de4795
<i>RK</i> _{32,33,34,35}	a34a20f5	33265d14	b19d0554	5142f434

plaintext		00010203	04050607	08090a0b	0c0d0e0f
initial whitening key		ffeeddcc			bbaa9988
after whitening		00010203	fbebdbc b	08090a0b	b7a79787
Round 1	input	00010203	fbebdbc b	08090a0b	b7a79787
	F-function	F_0		F_1	
	input	00010203		08090a0b	
	round key	f3e6cef9		8df75e38	
	after key add	f3e7ccfa		85fe5433	
	after S	290246e1		777de8e8	
	after M	547a3193		abf12070	
Round 2	input	af91ea58	08090a0b	1c56b7f7	00010203
	F-function	F_0		F_1	
	input	af91ea58		1c56b7f7	
	round key	41c06256		640ac51b	
	after key add	ee51880e		785c72ec	
	after S	cb5d2b0c		63a5edd2	
	after M	f51cebb3		82dfe347	
Round 3	input	fd15e1b8	1c56b7f7	82dee144	af91ea58
	F-function	F_0		F_1	
	input	fd15e1b8		82dee144	
	round key	6a27e20a		5a791b90	
	after key add	973203b2		d8a7fad4	
	after S	c2c7c6c2		be59e10d	
	after M	d8dfd8de		e15ea81c	
Round 4	input	c4896f29	82dee144	4ecf4244	fd15e1b8
	F-function	F_0		F_1	
	input	c4896f29		4ecf4244	
	round key	e8c528dc		00336ea3	
	after key add	2c4c47f5		4efc2ce7	
	after S	9da4dafc		43bce638	
	after M	b5b28e96		b65c519a	
Round 5	input	376c6fd2	4ecf4244	4b49b022	c4896f29
	F-function	F_0		F_1	
	input	376c6fd2		4b49b022	
	round key	59cd17c4		28565583	
	after key add	6ea17816		631fe5a1	
	after S	f26ad3e5		62af9f1b	
	after M	29f08afd		be01d127	
Round 6	input	673fc8b9	4b49b022	7a88be0e	376c6fd2
	F-function	F_0		F_1	
	input	673fc8b9		7a88be0e	
	round key	312a37cc		c08abd77	
	after key add	5615ff75		ba020379	
	after S	b39c8e58		2dd1e9a2	
	after M	5999a79e		0429b329	

Round 7	input	12d017bc 7a88be0e	3345dcfb 673fc8b9
	F-function	F_0	F_1
	input	12d017bc	3345dcfb
	round key	7e8e7eec	8be7e949
	after key add	6c5e6950	b8a235b2
	after S	8b737025	67a08eba
	after M	6ed11b09	dfd3cd32
Round 8	input	1459a507 3345dcfb	b8ec058b 12d017bc
	F-function	F_0	F_1
	input	1459a507	b8ec058b
	round key	d3f463d6	a0aad6aa
	after key add	c7adc6d1	1846d321
	after S	e7ee5a5f	9e97f1a1
	after M	8c9d011c	93684eec
Round 9	input	bfd8dde7 b8ec058b	81b85950 1459a507
	F-function	F_0	F_1
	input	bfd8dde7	81b85950
	round key	e75eb039	0d657eb9
	after key add	58866dde	8cdd27e9
	after S	4e821daf	59c56044
	after M	e6d6501e	6d5839b4
Round 10	input	5e3a5595 81b85950	79019cb3 bfd8dde7
	F-function	F_0	F_1
	input	5e3a5595	79019cb3
	round key	018002e2	9117d009
	after key add	5fba5777	e8164cba
	after S	612d8f7b	0185a49c
	after M	3a1b0e97	b9b479c8
Round 11	input	bba357c7 79019cb3	066ca42f 5e3a5595
	F-function	F_0	F_1
	input	bba357c7	066ca42f
	round key	9f98d11e	babee8cf
	after key add	243b86d9	bcd24ce0
	after S	f70f1144	cb72a481
	after M	28974052	4a6700b1
Round 12	input	5196dce1 066ca42f	145d5524 bba357c7
	F-function	F_0	F_1
	input	5196dce1	145d5524
	round key	b0369efa	d3aaef0d
	after key add	e1a0421b	c7f7ba29
	after S	6f7efd4f	72642dce
	after M	ffb5db32	907d3820

Round 13	input	f9d97f1d 145d5524	2bde6fe7 5196dce1
	F-function	F_0	F_1
	input	f9d97f1d	2bde6fe7
	round key	3438f93b	f9cea4a0
	after key add	cde18626	d210cb47
	after S	3f751141	ab28e0da
	after M	0a744c28	1c3e38a3
Round 14	input	1e29190c 2bde6fe7	4da8e442 f9d97f1d
	F-function	F_0	F_1
	input	1e29190c	4da8e442
	round key	68df9029	b869b4a7
	after key add	76f68925	f5c150e5
	after S	fe6db7e7	fc0c25f6
	after M	aaa2c803	c4315b8d
Round 15	input	817ca7e4 4da8e442	3de82490 1e29190c
	F-function	F_0	F_1
	input	817ca7e4	3de82490
	round key	24d6406d	e74bc550
	after key add	a5aae789	daa3e1c0
	after S	8d233818	2904757b
	after M	7bd4cced	eac2f0fb
Round 16	input	367c28af 3de82490	f4ebe9f7 817ca7e4
	F-function	F_0	F_1
	input	367c28af	f4ebe9f7
	round key	41c28193	16de4795
	after key add	77bea93c	e235ae62
	after S	7c4a935b	669b8953
	after M	598e6940	c119609f
Round 17	input	64664dd0 f4ebe9f7	4065c77b 367c28af
	F-function	F_0	F_1
	input	64664dd0	4065c77b
	round key	a34a20f5	33265d14
	after key add	c72c6d25	73439a6f
	after S	e7e61de7	788c85b4
	after M	2ac01b0a	c755adfa
Round 18	input	de2bf2fd 4065c77b	f1298555 64664dd0
	F-function	F_0	F_1
	input	de2bf2fd	f1298555
	round key	b19d0554	5142f434
	after key add	6fb6f7a9	a06b7161
	after S	b44d648c	7e99ea2a
	after M	ac7738f2	12d0c82d
	output	de2bf2fd ec12ff89	f1298555 76b685fd
	final whitening key	77665544	33221100
	after whitening	de2bf2fd 9b74aacd	f1298555 459494fd
	ciphertext	de2bf2fd 9b74aacd	f1298555 459494fd

192-bit key:

key	ffeeddcc	bbaa9988	77665544	33221100
	f0e0d0c0	b0a09080		
plaintext	00010203	04050607	08090a0b	0c0d0e0f
ciphertext	e2482f64	9f028dc4	80dda184	fde181ad
L_L	db05415a	800082db	7cb8186c	d788c5f3
L_R	1ca9b2e1	b4606829	c92dd35e	2258a432
$WK_{0,1,2,3}$	0f0e0d0c	0b0a0908	77777777	77777777
$RK_{0,1,2,3}$	4d3bfd1b	7a1f5dfa	0fae6e7c	c8bf3237
$RK_{4,5,6,7}$	73c2eeb8	dd429ec5	e220b3af	c9135e73
$RK_{8,9,10,11}$	38c46a07	fc2ce4ba	370abf2d	b05e627b
$RK_{12,13,14,15}$	38351b2f	74bd6e1e	1b7c7dce	92cfc98e
$RK_{16,17,18,19}$	509b31a6	4c5ad53c	6fc2ba33	e1e5c878
$RK_{20,21,22,23}$	419a74b9	1dd79e0e	240a33d2	9dabfd09
$RK_{24,25,26,27}$	6e3ff82a	74ac3ffd	b9696e2e	cc0b3a38
$RK_{28,29,30,31}$	ed785cbd	9c077c13	04978d83	2ec058ba
$RK_{32,33,34,35}$	4bbd5f6a	31fe8de8	b76da574	3a6fa8e7
$RK_{36,37,38,39}$	521213ce	4f1f59d8	c13624f6	ee91f6a4
$RK_{40,41,42,43}$	17f68fde	f6c360a9	6288bc72	c0ad856b

plaintext		00010203	04050607	08090a0b	0c0d0e0f
initial whitening key		0f0e0d0c		0b0a0908	
after whitening		00010203	0b0b0b0b	08090a0b	07070707
Round 1	input	00010203	0b0b0b0b	08090a0b	07070707
	F-function	F_0		F_1	
	input	00010203		08090a0b	
	round key	4d3bfd1b		7a1f5dfa	
	after key add	4d3aff18		721657f1	
	after S	43c58e9e		ed85d736	
	after M	b5021a3b		c397f62b	
Round 2	input	be091130	08090a0b	c490f12c	00010203
	F-function	F_0		F_1	
	input	be091130		c490f12c	
	round key	0fae6e7c		c8bf3237	
	after key add	b1a77f4c		0c2fc31b	
	after S	f3d10ba4		13d83a3d	
	after M	9fba69c1		6683cae3	
Round 3	input	97b363ca	c490f12c	6682c8e0	be091130
	F-function	F_0		F_1	
	input	97b363ca		6682c8e0	
	round key	73c2eeb8		dd429ec5	
	after key add	e4718d72		bbc05625	
	after S	79ea66ed		f47b0d7a	
	after M	61c21ea5		120e06e2	
Round 4	input	a552ef89	6682c8e0	ac0717d2	97b363ca
	F-function	F_0		F_1	
	input	a552ef89		ac0717d2	
	round key	e220b3af		c9135e73	
	after key add	47725c26		651449a1	
	after S	daeda541		355c651b	
	after M	28a43c63		cb1ab573	
Round 5	input	4e26f483	ac0717d2	5ca9d6b9	a552ef89
	F-function	F_0		F_1	
	input	4e26f483		5ca9d6b9	
	round key	38c46a07		fc2ce4ba	
	after key add	76e29e84		a0853203	
	after S	fe663e39		7edcc7c6	
	after M	5ce7dafe		ac7f4e3e	
Round 6	input	f0e0cd2c	5ca9d6b9	092da1b7	4e26f483
	F-function	F_0		F_1	
	input	f0e0cd2c		092da1b7	
	round key	370abf2d		b05e627b	
	after key add	c7ea7201		b973c3cc	
	after S	e77f9fda		174a3a46	
	after M	b9869270		8fc7e089	

Round 7	input	e52f44c9 092da1b7	c1e1140a f0e0cd2c
	F-function	F_0	F_1
	input	e52f44c9	c1e1140a
	round key	38351b2f	74bd6e1e
	after key add	dd1a5fe6	b55c7a14
	after S	c5496150	5aa5c15c
	after M	33d8590f	e62eb913
Round 8	input	3af5f8b8 c1e1140a	16ce743f e52f44c9
	F-function	F_0	F_1
	input	3af5f8b8	16ce743f
	round key	1b7c7dce	92cfc98e
	after key add	21898576	8401bdb1
	after S	a118dc09	3949b1f3
	after M	f091202d	04f9e827
Round 9	input	31703427 16ce743f	e1d6acee 3af5f8b8
	F-function	F_0	F_1
	input	31703427	e1d6acee
	round key	509b31a6	4c5ad53c
	after key add	61eb0581	ad8c79d2
	after S	2a8d3304	eeffc072
	after M	f9639a90	8bebf3d
Round 10	input	efadeeaf e1d6acee	b11e0685 31703427
	F-function	F_0	F_1
	input	efadeeaf	b11e0685
	round key	6fc2ba33	e1e5c878
	after key add	806f549c	50fbcefd
	after S	cd5eeb61	25d7fe02
	after M	a100e35b	26a4e16d
Round 11	input	40d64fb5 b11e0685	17d4d54a efadeeaf
	F-function	F_0	F_1
	input	40d64fb5	17d4d54a
	round key	419a74b9	1dd79e0e
	after key add	014c3b0c	0a034b44
	after S	49a4c013	b4c6c912
	after M	51c0208f	f1a2c339
Round 12	input	e0de260a 17d4d54a	1e0f2d96 40d64fb5
	F-function	F_0	F_1
	input	e0de260a	1e0f2d96
	round key	240a33d2	9dabfd09
	after key add	c4d415d8	83a4d09f
	after S	801beebe	86b8f8ed
	after M	8a9aef34	3e451646

Round 13	input	9d4e3a7e 1e0f2d96	7e9359f3 e0de260a
	F-function	F_0	F_1
	input	9d4e3a7e	7e9359f3
	round key	6e3ff82a	74ac3ffd
	after key add	f371c254	0a3f660e
	after S	29ea68e8	b4f530a8
	after M	17524741	4b8c607e
Round 14	input	095d6ad7 7e9359f3	ab524674 9d4e3a7e
	F-function	F_0	F_1
	input	095d6ad7	ab524674
	round key	b9696e2e	cc0b3a38
	after key add	b03404f9	67597c4c
	after S	152a2f03	52161e39
	after M	f7ee818b	7902f3eb
Round 15	input	897dd878 ab524674	e44cc995 095d6ad7
	F-function	F_0	F_1
	input	897dd878	e44cc995
	round key	ed785cbd	9c077c13
	after key add	640584c5	784bb586
	after S	459d9e10	636b5a11
	after M	4034defc	0228bdd4
Round 16	input	eb669888 e44cc995	0b75d703 897dd878
	F-function	F_0	F_1
	input	eb669888	0b75d703
	round key	04978d83	2ec058ba
	after key add	eff1150b	25b58fb9
	after S	90e4ee38	e7691f3b
	after M	4a678609	05b2b4a9
Round 17	input	ae2b4f9c 0b75d703	8ccf6cd1 eb669888
	F-function	F_0	F_1
	input	ae2b4f9c	8ccf6cd1
	round key	4bbd5f6a	31fe8de8
	after key add	e59610f6	bd31e139
	after S	f6a5286d	b15d7589
	after M	720df49d	bad65e22
Round 18	input	7978239e 8ccf6cd1	51b0c6aa ae2b4f9c
	F-function	F_0	F_1
	input	7978239e	51b0c6aa
	round key	b76da574	3a6fa8e7
	after key add	ce1586ea	6bdf6e4d
	after S	919c117f	283aaa43
	after M	ef24fe56	08916103

Round 19	input	63eb9287	51b0c6aa	a6ba2e9f	7978239e
	F-function	F_0		F_1	
	input	63eb9287		a6ba2e9f	
	round key	521213ce		4f1f59d8	
	after key add	31f98149		e9a57747	
	after S	5d03e265		3c8d7bda	
	after M	b7464b63		e1d086a7	
Round 20	input	e6f68dc9	a6ba2e9f	98a8a539	63eb9287
	F-function	F_0		F_1	
	input	e6f68dc9		98a8a539	
	round key	c13624f6		ee91f6a4	
	after key add	27c0a93f		7639539d	
	after S	20b5938b		09893194	
	after M	3cae819e		b603c454	
Round 21	input	9a14af01	98a8a539	d5e856d3	e6f68dc9
	F-function	F_0		F_1	
	input	9a14af01		d5e856d3	
	round key	17f68fde		f6c360a9	
	after key add	8de220df		232b367a	
	after S	6666bff2		b383a1bd	
	after M	7ae08a5d		662b2c4d	
Round 22	input	e2482f64	d5e856d3	80dda184	9a14af01
	F-function	F_0		F_1	
	input	e2482f64		80dda184	
	round key	6288bc72		c0ad856b	
	after key add	80c09316		407024ef	
	after S	cdb5f1e5		fbe99290	
	after M	3d9dac60		108259db	
	output	e2482f64	e875fab3	80dda184	8a96f6da
	final whitening key	77777777		77777777	
	after whitening	e2482f64	9f028dc4	80dda184	fde181ad
	ciphertext	e2482f64	9f028dc4	80dda184	fde181ad

256-bit key:

key	ffeeddcc	bbaa9988	77665544	33221100
	f0e0d0c0	b0a09080	70605040	30201000
plaintext	00010203	04050607	08090a0b	0c0d0e0f
ciphertext	a1397814	289de80c	10da46d1	fa48b38a
L_L	477e8f09	66ee5378	2cc2be04	bf55e28f
L_R	d6c10b89	4eeab575	84bd5663	cc933940
$WK_{0,1,2,3}$	0f0e0d0c	0b0a0908	07060504	03020100
$RK_{0,1,2,3}$	58f02029	15413cd0	1b0c41a4	e4bacd0f
$RK_{4,5,6,7}$	6c498393	8846231b	1fc716fc	7c81a45b
$RK_{8,9,10,11}$	fa37c259	0e3da2ee	aacf9abb	8ec0aad9
$RK_{12,13,14,15}$	b05bd737	8de1f2d0	8ffee0f6	b70b47ea
$RK_{16,17,18,19}$	581b3e34	03263f89	2f7100cd	05cee171
$RK_{20,21,22,23}$	b523d4e9	176d7c44	6d7ba5d7	f797b2f3
$RK_{24,25,26,27}$	25d80df2	a646bba2	6a3a95e1	3e3a47f0
$RK_{28,29,30,31}$	b304eb20	44f8824e	c7557cbc	47401e21
$RK_{32,33,34,35}$	d71ff7e9	aca1fb0c	2deff35d	6ca3a830
$RK_{36,37,38,39}$	4dd7cfb7	ae71c9f6	4e911fef	90aa95de
$RK_{40,41,42,43}$	2c664a7a	8cb5cf6b	14c8de1e	43b9caef
$RK_{44,45,46,47}$	568c5a33	07ef7ddd	608dc860	ac9e50f8
$RK_{48,49,50,51}$	c0c18358	4f53c80e	33e01cb9	80251e1c

plaintext		00010203	04050607	08090a0b	0c0d0e0f
initial whitening key		0f0e0d0c		0b0a0908	
after whitening		00010203	0b0b0b0b	08090a0b	07070707
Round 1	input	00010203	0b0b0b0b	08090a0b	07070707
	F-function	F_0		F_1	
	input	00010203		08090a0b	
	round key	58f02029		15413cd0	
	after key add	58f1222a		1d4836db	
	after S	4ee41927		2c78a1ac	
	after M	2db2101b		d87ee718	
Round 2	input	26b91b10	08090a0b	df79e01f	00010203
	F-function	F_0		F_1	
	input	26b91b10		df79e01f	
	round key	1b0c41a4		e4bacd0f	
	after key add	3db55ab4		3bc32d10	
	after S	aa5afadb		0f1e1928	
	after M	317e029c		c0cc96ba	
Round 3	input	39770897	df79e01f	c0cd94b9	26b91b10
	F-function	F_0		F_1	
	input	39770897		c0cd94b9	
	round key	6c498393		8846231b	
	after key add	553e8b04		488bb7a2	
	after S	5487484e		d84876a0	
	after M	c3a7ac1d		7ae05884	
Round 4	input	1cde4c02	c0cd94b9	5c594394	39770897
	F-function	F_0		F_1	
	input	1cde4c02		5c594394	
	round key	1fc716fc		7c81a45b	
	after key add	03195afe		20d8e7cf	
	after S	c607fa95		12f002c9	
	after M	5edee0ce		4cfb0e90	
Round 5	input	9e137477	5c594394	758c0607	1cde4c02
	F-function	F_0		F_1	
	input	9e137477		758c0607	
	round key	fa37c259		0e3da2ee	
	after key add	6424b62e		7bb1a4e9	
	after S	4592c8d2		46f3a044	
	after M	adfd33ae		42450650	
Round 6	input	f1a4703a	758c0607	5e9b4a52	9e137477
	F-function	F_0		F_1	
	input	f1a4703a		5e9b4a52	
	round key	aacf9abb		8ec0aad9	
	after key add	5b6bea81		d05be08b	
	after S	22285e04		f822d448	
	after M	0fa52ed4		aa7a0a9c	

Round 7	input	7a2928d3 5e9b4a52	34697eeb f1a4703a
	F-function	F_0	F_1
	input	7a2928d3	34697eeb
	round key	b05bd737	8de1f2d0
	after key add	ca72ffe4	b9888c3b
	after S	23ed8e68	172b59c0
	after M	8b158630	334e2af2
Round 8	input	d58ecc62 34697eeb	c2ea5ac8 7a2928d3
	F-function	F_0	F_1
	input	d58ecc62	c2ea5ac8
	round key	8ffee0f6	b70b47ea
	after key add	5a702c94	75e11d22
	after S	facf9d64	586f2c19
	after M	72c2027e	a582d5f0
Round 9	input	46ab7c95 c2ea5ac8	dfabfd23 d58ecc62
	F-function	F_0	F_1
	input	46ab7c95	dfabfd23
	round key	581b3e34	03263f89
	after key add	1eb042a1	dc8dc2aa
	after S	177afd6a	57664735
	after M	51d5740a	110287d7
Round 10	input	933f2ec2 dfabfd23	c48c4bb5 46ab7c95
	F-function	F_0	F_1
	input	933f2ec2	c48c4bb5
	round key	2f7100cd	05cee171
	after key add	bc4e2e0f	c142aac4
	after S	e0434cd9	22fd2380
	after M	a768d32a	b6ae4f2b
Round 11	input	78c32e09 c48c4bb5	f00533be 933f2ec2
	F-function	F_0	F_1
	input	78c32e09	f00533be
	round key	b523d4e9	176d7c44
	after key add	cde0fae0	e7684ffa
	after S	3fd410d4	02ef5310
	after M	08bd9b01	2fdb3f65
Round 12	input	cc31d0b4 f00533be	bce411a7 78c32e09
	F-function	F_0	F_1
	input	cc31d0b4	bce411a7
	round key	6d7ba5d7	f797b2f3
	after key add	a14a7563	4b73a354
	after S	1b512562	c94a71eb
	after M	7c2c762b	81ca0b59

Round 13	input	8c294595 bce411a7	f9092550 cc31d0b4
	F-function	F_0	F_1
	input	8c294595	f9092550
	round key	25d80df2	a646bba2
	after key add	a9f14867	5f4f9ef2
	after S	93e47852	5c26cae5
	after M	4a87c858	54bc68d5
Round 14	input	f663d9ff f9092550	988db861 8c294595
	F-function	F_0	F_1
	input	f663d9ff	988db861
	round key	6a3a95e1	3e3a47f0
	after key add	9c594c1e	a6b7ff91
	after S	58ff39b0	054d1d75
	after M	d82301d4	085d5025
Round 15	input	212a2484 988db861	847415b0 f663d9ff
	F-function	F_0	F_1
	input	212a2484	847415b0
	round key	b304eb20	44f8824e
	after key add	922ecfa4	c08c97fe
	after S	86d2c9a0	b5ff567d
	after M	dbf56073	87e2a6a2
Round 16	input	4378d812 847415b0	71817f5d 212a2484
	F-function	F_0	F_1
	input	4378d812	71817f5d
	round key	c7557cbc	47401e21
	after key add	842da4ae	36c1617c
	after S	9e19b889	a10c5414
	after M	6791a3e3	e177d3a8
Round 17	input	e3e5b653 71817f5d	c05df72c 4378d812
	F-function	F_0	F_1
	input	e3e5b653	c05df72c
	round key	d71ff7e9	aca1fb0c
	after key add	34fa41ba	6cfc0c20
	after S	d4e1be2d	32bc13bf
	after M	2743ef2d	6fec0aab
Round 18	input	56c29070 c05df72c	2c94d2b9 e3e5b653
	F-function	F_0	F_1
	input	56c29070	2c94d2b9
	round key	2def35d	6ca3a830
	after key add	7b2d632d	40377a89
	after S	56193719	fb13c1b7
	after M	ee6316fa	5e3245b7

Round 19	input	2e3ee1d6 2c94d2b9	bdd7f3e4 56c29070
	F-function	F_0	F_1
	input	2e3ee1d6	bdd7f3e4
	round key	4dd7cfb7	ae71c9f6
	after key add	63e92e61	13a63a12
	after S	373c4c54	8fe6c54b
	after M	87aab08e	8f8d16f3
Round 20	input	ab3e6237 bdd7f3e4	d94f8683 2e3ee1d6
	F-function	F_0	F_1
	input	ab3e6237	d94f8683
	round key	4e911fef	90aa95de
	after key add	e5af7dd8	49e5135d
	after S	f6ad88be	65f68f77
	after M	0889df33	f418c84f
Round 21	input	b55e2cd7 d94f8683	da262999 ab3e6237
	F-function	F_0	F_1
	input	b55e2cd7	da262999
	round key	2c664a7a	8cb5cf6b
	after key add	993866ad	5693e6f2
	after S	2c2b6cee	0df150e5
	after M	8999e772	da5415d2
Round 22	input	50d661f1 da262999	716a77e5 b55e2cd7
	F-function	F_0	F_1
	input	50d661f1	716a77e5
	round key	14c8de1e	43b9caef
	after key add	441ebfef	32d3bd0a
	after S	12b052ac	c7bbb182
	after M	f5efd89e	744a9ced
Round 23	input	2fc9f107 716a77e5	c114b03a 50d661f1
	F-function	F_0	F_1
	input	2fc9f107	c114b03a
	round key	568c5a33	07ef7ddd
	after key add	7945ab34	c6fbcde7
	after S	a2a77e2a	4cd7e238
	after M	e84f6d9b	ce67e20a
Round 24	input	99251a7e c114b03a	9eb183fb 2fc9f107
	F-function	F_0	F_1
	input	99251a7e	9eb183fb
	round key	608dc860	ac9e50f8
	after key add	f9a8d21e	322fd303
	after S	f84572b0	c7d8f1c6
	after M	20634b77	591b3f55

Round 25	input	e177fb4d 9eb183fb	76d2ce52 99251a7e
	F-function	F_0	F_1
	input	e177fb4d	76d2ce52
	round key	c0c18358	4f53c80e
	after key add	21b67815	3981065c
	after S	a14dd39c	c8e20aa5
	after M	3f88fbef	89ff5caf
Round 26	input	a1397814 76d2ce52	10da46d1 e177fb4d
	F-function	F_0	F_1
	input	a1397814	10da46d1
	round key	33e01cb9	80251e1c
	after key add	92d964ad	90ff58cd
	after S	864445ee	9a8e803f
	after M	5949235a	183d49c7
	output	a1397814 2f9bed08	10da46d1 f94ab28a
	final whitening key	07060504	03020100
	after whitening	a1397814 289de80c	10da46d1 fa48b38a
	ciphertext	a1397814 289de80c	10da46d1 fa48b38a